

Thermal Image Inspection System for capsealing for induction capsealing integrity

CVC FIS20-M / FIS20-L



CVC FIS20 Series Thermal image inspection system, adopting the latest thermal imaging technology along with a thermal image camera, is able to perform multi-point temperature checks and converts the data into thermal images for aluminum foil sealing inspection.

CVC FIS20 can easily integrate with an induction capsealing machine to inspect aluminum foil seals immediately after sealing, ensuring product quality. It comes in two models, mid-wave (CVC FIS20-M) and long-wave (CVC FIS20-L), to suit different types of bottle caps.

SYSTEM FEATURES

- Stainless steel construction for durability
- Utilizes advanced thermal imaging technology
- Equipped with a large floor-standing bottle conveyor system
- 15" PC touch screen with the ability to save multiple teaching modes.
- Siemens PLC control system
- Inspection capacity: up to 200 bottles per minute (with optional bottle screw set)
- Compatible with various plastic bottle cap types: mid-wave and long-wave models for CT caps, mid-wave model for CRC caps
- Applicable bottle sizes: maximum bottle diameter 120mm, maximum bottle height 200mm
- Comply to US FDA 21CFR Part 11, audit trail and production reports available
- Easily integrated into various bottle packaging lines
- Inspection capability
 - bent or damaged foil, missing foil, damaged edge or edges, upside-down liner
 - loose or crooked caps
 - overheating or under-heating
 - fallen containers

2000TS

FIS20-M / L



Basic specifications:

Machine specifications	FIS20-M	FIS20-L
Length, width and height	820(mm)x500(mm)x1730(mm)	
Power source	220V, 50/60Hz, single phase	
Power consumption	2.3 KW	
Air pressure	6kg/cm ²	
Air consumption	100L/min(3.5CFM)	
Technical specifications		
Maximum line speed	16 M/minute	
Maximum bottle height	200 mm	
Maximum bottle width	120 mm	
Maximum cap diameter	60 mm	
Process control		
Immediate accept/reject of each bottle	Yes	
Rejection unit(with alarm Gate)	Air Punch / cylinder (Controlled by PLC)	
Rejection verification	Optional	
Separator wheel control (front of induction capsealer)	Yes (standard)	Yes (standard)
Output(capacity)	up to 200BPM (when optional bottle feed screw is selected)	up to 120BPM
Change bottles	—	Cylinder-module
System support		
CVC technical support	Yes	
Troubleshooting application	Yes	
Documentation	Operation manual with full validation documentation (Optional)	
Regulatory compliance	21 CFR part 11 (Optional)	
Support OPC-UA	Optional	
System Hardware		
Camera	IR Camera	
Controller	PC-Panel / PLC	
Structure	Stainless Steel Construction	
Height adjustment	Camera height adjustment (with motor)	
UPS	Optional	

Technical data contained in this material are not binding and may be subject to change without prior notice.

TECHNICAL SPECIFICATIONS

AVAILABLE OPTIONS

- 3-Color Stack Tower Light
- Bottle Feed Screw
- 21CFR Part 11 Compliant
- OPC UA Server
- Bottle Reject Verification

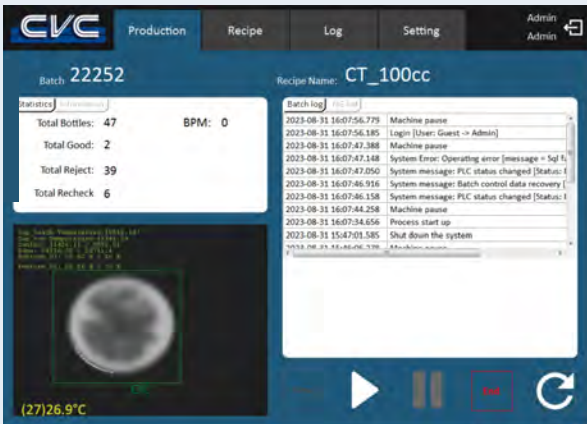

Pass



Fail



MACHINE LAYOUTS

Top View

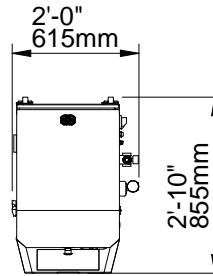

Front View

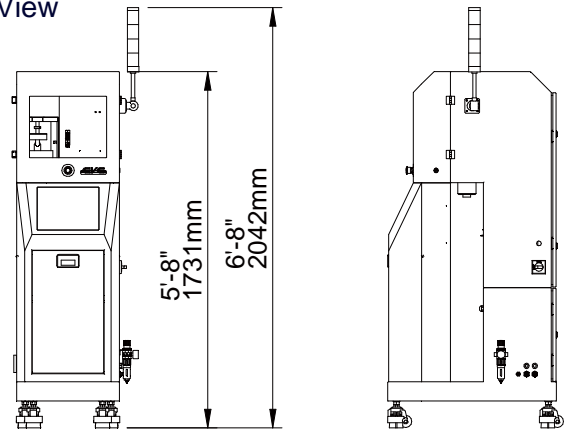

Technical data contained in this material are not binding and may be subject to change without prior notice.



Contact Us

USA

10861 Business Drive, Fontana, CA 92337
 Phone: +1 (909) 355-0311
www.cvcusa.com ; www.cvctechnologies.com
sales@cvcusa.com

Taiwan-Asia Pacific Headquarters

Phone: +886 (4) 2496-3666
sales@cvctechnologies.com

India

Phone: +91 (22) 2562-1242, +91 (22) 2562-1243
sales@cvctechnologies.com

China

Phone: +86 (512) 8363-6368
sales@cvctechnologies.com

